

w2 80.0 Plury

Tons 10.0 - 16.0

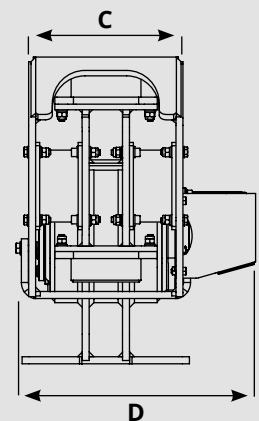

Model	PLURY W2 80.0	PLURY W2 80.0	PLURY W2 80.0
A (mm)	970	970	970
B (mm)	650	650	650
C (mm)	330	330	330
D (mm)	490	490	490
Peso / Weight (Kg)	362	362	362
Motore / Engine (CC)	21.1	27	32.2
Portata Olio Hydraulic Fluid Flow Rate (L/Min)	45	58	69
Pressione / Pressure (BAR)	150/220	150/220	150/220
Frequenza Vibrazione Vibration Rate (RPM)	2.133	2.148	2.143
Forza centrifuga Centrifugal Force (Kn)	80	80	80
Hertz	36	36	36

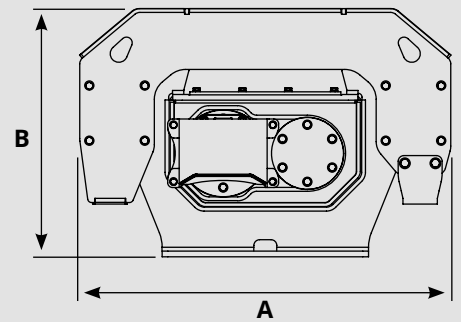

MACHINE ATTACHMENTS

Tons 8.0 - 40.0



ATTACCHI MACCHINE / MACHINE ATTACHMENTS

ADATTATORE PER ATTACCO RAPIDO
ADAPTER FOR QUICK COUPLING



ATTACCO MACCHINA FISSO
FIXED COUPLING TO THE MACHINE



PIASTRA ATTACCO MACCHINA
BOLTED PLATE TO THE MACHINE COUPLING

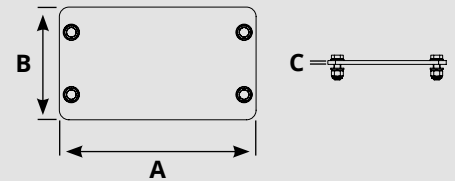

TOK ATTACCO RAPIDO 8/40 TON
TOK QUICK COUPLER 8/40 TON

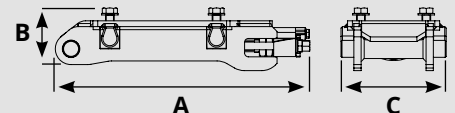

TOK ADATTATORE 8/40 TON
TOK ADAPTER 8/40 TON

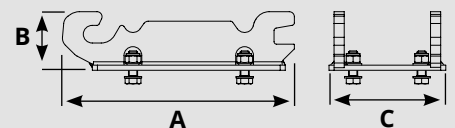

	Model	A mm	B mm	C mm	Kg.	€
1	ADAPTER FOR QUICK COUPLING	/	/	/	/	
2	FIXED COUP. TO THE MACHINE	/	/	/	/	
3	BOLTED PLATE TO MACHINE COUPLING	640	340	15	29	
4	TOK QUICK COUPLER 8/40 ton	805	160	480	140	
5	TOK ADAPTER 8/40 ton	750	175	475	88	